

SPECIFICHE GENERALI
GENERAL SPECIFICATIONS

Materiale contenitore Housing material	Ottone naturale Natural Brass
Funzionamento Operation	NC con i due componenti vicini NC when the two components are near
Temp. di funzionamento Operating temperature	-25°C ÷ +50°C
Grado di protezione IP degree	Certificato IPx2 (dichiarato IP65 da Cooper CSA) Certified IPx2 (declared IP65 by Cooper CSA)
V max	42,4 Vpeak - 60 Vdc
I max	1 A
W max	10 W
Identificazione Identification	Numero seriale/lotto su ogni componente Serial number/batch on each component

I contatti magnetici sono componenti passivi, le grandezze elettriche indicate sono le massime applicabili
Magnetic contacts are passive components, max applicable voltage and current are displayed in table

EN50131-2-6

GR 3

CL III



INSTALLAZIONE CONFORME ALLA NORMA
INSTALLATION AS PER STANDARD

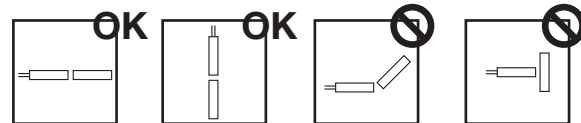
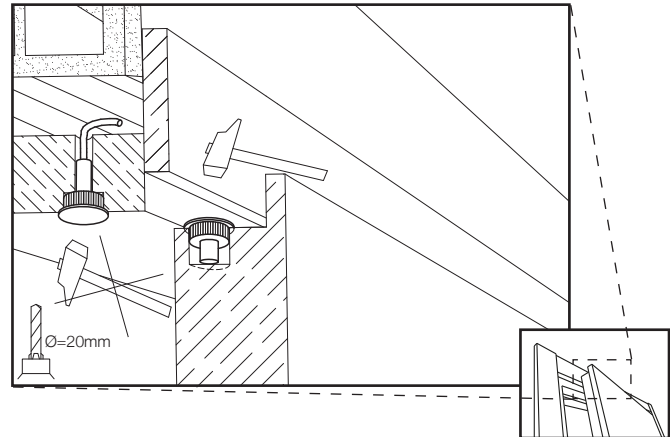

La certificazione decade per installazioni diverse da quelle rappresentate nelle figure.
Certification is void if the devices are installed differently.

DISTANZE OPERATIVE / OPERATIONAL APPROACH AND REMOVAL DISTANCES

Su superfici non ferromagnetiche installare i due corpi a distanza Y inferiore a 20mm (distanza raccomandata 6mm), su superfici ferromagnetiche a distanza Y inferiore a 12mm (distanza raccomandata 6mm). Le distanze operative riportate in tabella per l'asse Z sono state calcolate con i corpi installati alla distanza raccomandata.

Install the two components at Y distance less than 20mm (recommended 6mm) on non-ferromagnetic surfaces, at Y distance less than 12mm (recommended 6mm) on ferromagnetic surfaces. The operating distances displayed in table for the axis Z have been calculated with the components mounted at the recommended distance.

Asse / Axis	Z		Y	
Azione / Action				
Contatto / Contact				
Superfici non ferromagnetiche Non-ferromagnetic surfaces	17 mm	27 mm	20 mm	36 mm
Superfici ferromagnetiche Ferromagnetic surfaces	8 mm	16 mm	12 mm	22 mm
Tolleranze / Tolerance	-0% +50%	+0% -30%	-0% +50%	+0% -30%

INDICAZIONI DI FISSAGGIO / FIXING INSTRUCTIONS

Fissare le parti tenendo conto delle distanze operative riportate in tabella.
Fix the elements paying attention to the operational approach and removal distance.

COLLEGAMENTO / WIRING

