



# SHP-1520FW

In-ceiling Housing



## Key Features

- Dimension : W212.1 X H164.5mm
- Weight : 450g
- Temperature : -10°C ~ 50°C
- Material : PC
- Color : White

# SHP-1520FW

In-ceiling Housing

## Specifications

### Environmental

Operating Temperature / Humidity	-10°C ~ 50°C / 0 ~ 90% RH
----------------------------------	---------------------------

### Mechanical

Color	White
Material	Polycarbonate
RAL code	RAL9003
Product dimensions / weight	Ø212.1 X H164.5 / 450g
Supported products	QNP-6250, QNP-6320

# SHP-1520FW

In-ceiling Housing

CAD

Unit: mm [inch]

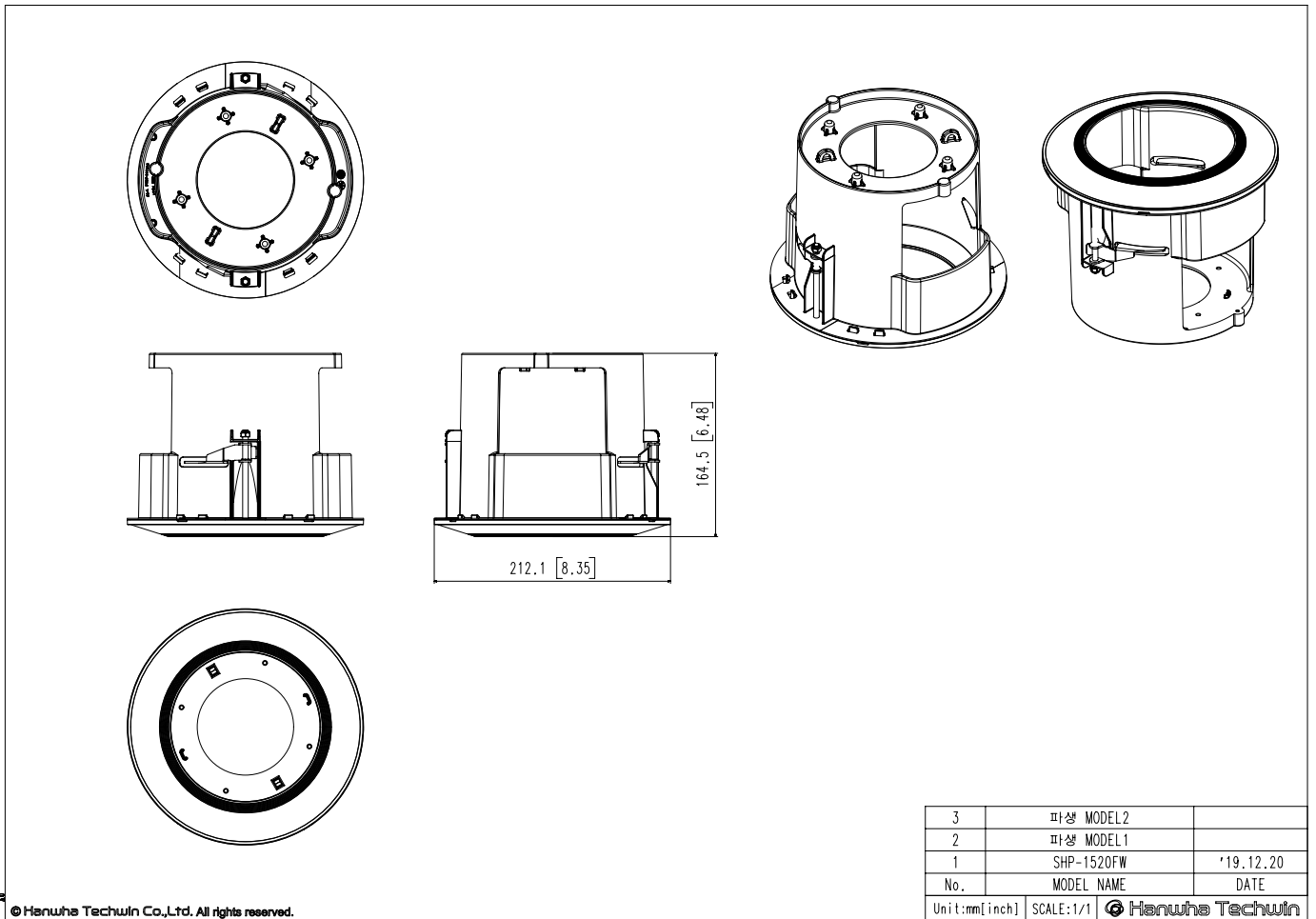

© Hanwha Techwin Co.,Ltd. All rights reserved.